



400 series

flexible container
handling systems

400 series

The 400 Series from TREPKO is a range of servo driven flexible container handling systems that offer themselves to a wide variety of filling & sealing applications. This flexible machine series can handle a considerable variety of packaging types including troublesome parallel sided containers. Recent developments in the series include applications to seal cardboard sandwich packaging, plastic alcoholic beverages and high speed filling lines for the salads industry.

All TREPKO servo conveyors are designed to minimise the number of change parts required between packaging changeovers and therefore maximising production time & output. To achieve long term flexibility, on the whole lines are built in a modular format enabling additional assemblies to be added when demand necessitates.

The servo machines from TREPKO rely on a fully stainless steel construction which is combined with modern drive systems for a smooth and reliable operation.



Design Example

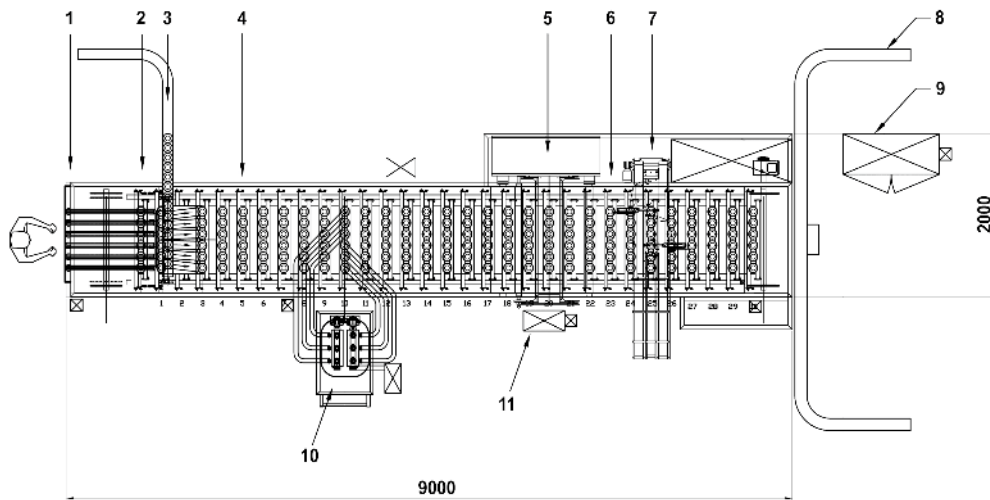

- | | | |
|------------------------------|----------------------------------|--------------------------------|
| 1. Auto Cup Loader | 5. Reel Feed / Heat Seal Station | 9. Electrical Cabinet |
| 2. Dispense From Auto-Loader | 6. Date Coder | 10. Wheel In/Out Depositor |
| 3. In-feed Conveyor | 7. Auto Lid Loader | 11. Operator Control Panel/HMI |
| 4. Cup Detect | 8. Eject Conveyor | |

Options

Container Dispense Module
 Bulk Container Loading Assemblies
 Filling Track Sections
 Volumetric Filling Systems. (with standard Trepko Options CIP etc.)
 Sealing Systems – both pre-cut and seal from roll stock
 Clip on Over-lid Assemblies
 Bulk Clip on Over-lidding Assemblies
 Recipe Screening function to allow instant push of the button product changes
 Single or Twin Index Profiles
 Modem Connection

Typical Applications

- Bulk Salads Line
- Multi-fill desserts
- High Speed Filling Lines
- Vodka Shots
- Contact Lenses
- Sandwich Systems





Worldwide supplier  of filling/packaging machines



info@trepko.com
www.trepko.com