

The Trepko PMG 10 Series machine is a semi-automatic filling machine designed for the bulk filling of boxes with butter type products.

Constructed from food grade stainless steel the machine is equipped with a product compensator directly connected to the filler which ensures a constant and even supply of product between the 3rd party process equipment and the Trepko filler. The PMG-10 machine continually monitors the flow of product from the compensator and can adjust the speed and give feedback to the Trepko filler accordingly. This feedback and adjustment is also used during the CIP process to control the flow of the cleaning agent.

The machines filling process is as follows:

1. The box is pre-folded and then manually placed on the table of the machine.
2. The box is lined with a protective foil bag.
3. The table on which the box is located is automatically moved up under the filling nozzle. The opening of the foil bag is then manually placed around the filling nozzle.
4. The product is then filled. During the filling process the table on which the box is sat moves down until the required level of product is obtained.
5. The filled box is then moved manually from the filling position & on to the outfeed roller conveyor with optional check-weigher. In this position the check-weigher weights the box and provides feedback to the dosing unit to adjust the fill weight if necessary. After achieving the correct weight the box is manually closed.

As an alternative it is possible to equip the machine with a double scroll chute arrangement where the scrolls forced the product to the filling head. In this version the carton is filled in the horizontal position, i.e. the carton opening faces the filling head. Once the filling is completed the carton is moved pneumatically through 90°. This system is not integrated with a weighing cell so extra filling must be done manually following automatic filling process.



PMG 10 series
semi-automatic butter bulk
packaging machine

Trepko

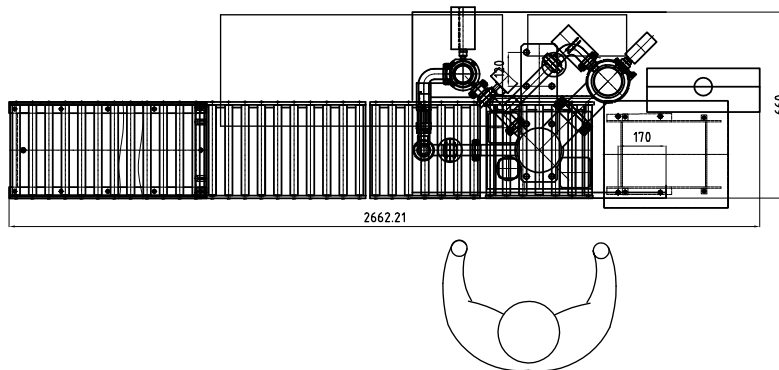
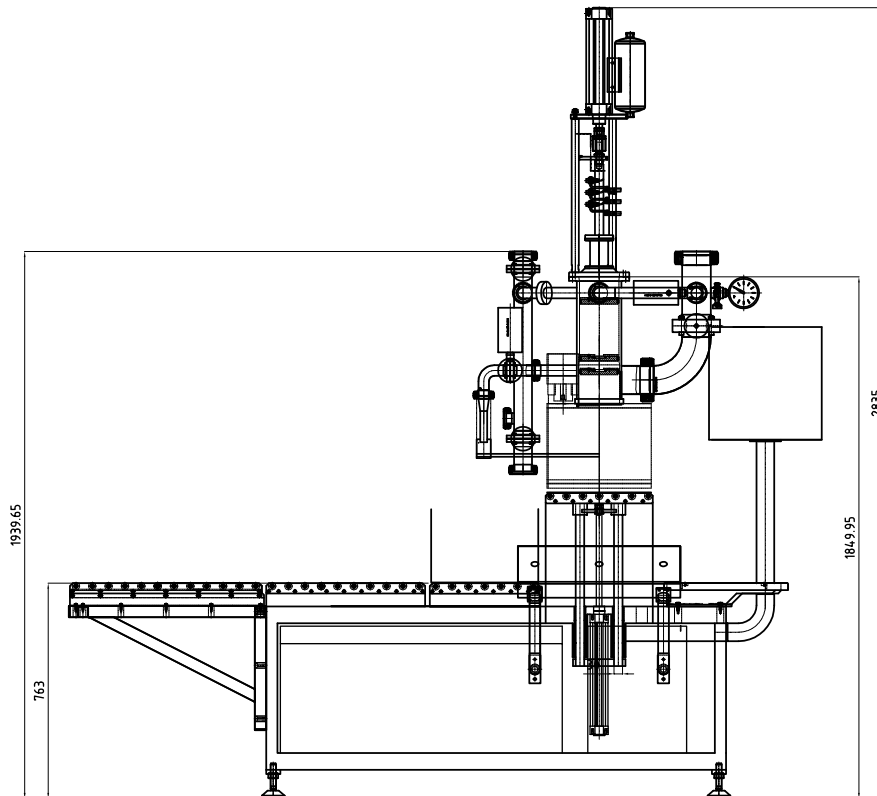

Scandinavia & Western Europe

Trepko A/S
Energivej 30
2750 Ballerup
Denmark
Phone: +45 43 99 22 44
Fax: +45 43 99 26 55

United Kingdom, Ireland, Australia and New Zealand

Trepko (UK) Limited
Marshall Way
Heapham Road Ind. Estate
Gainsborough, Lincolnshire
England, DN21 1GD
United Kingdom
Phone: +44 1427 612244
Fax: +44 1427 617797

Central & Eastern Europe

Trepko Sp. z o.o.
ul. Roosevelta 116
62-200 Gniezno
Poland
Phone: +48 61 426 50 41
Fax: +48 61 426 50 68

North & Latin America

Trepko Inc.
Sunstate Centre
4893 West Waters Ave
Suite C-F
Tampa, FL, 33634
USA
Phone: +1 813 443 0794

Sub-Saharan Africa

130 Jan van Riebeeck Drive
Paarl, Western Cape, 7646
South Africa
Phone: +27 (0) 21 862 2192
Fax: +27 (0) 21 862 4605

Middle East & North Africa

Trepko A/S - sales office
P.O. Box 58
Al-Andalus 11817 Cairo
Egypt
Mobile: +20 122 32 19 274

Brazil

Trepko do Brasil Ltda
Rua Brasholanda, 240
Pinhais, Paraná
Brazil
Zip code 83322-070
Phone: +55 41 3513-5100
Fax: +55 41 3513-5101

Technical specifications

Output speed:	1,500 kg/hour
Product:	Butter
Dosing and product feed:	Compensator/ Double scroll chute
Maximum box dimensions:	400 x 300 x 300 mm
Power supply:	1x230V + N + PE, 50 Hz
Power consumption:	0,5 kVA
Air consumption:	5 l/min
Manual carton placement and closing	
Integrated weighing cell (optional)	